

Instruções para instalação

Corrediça Excel

Dimensões para fixação

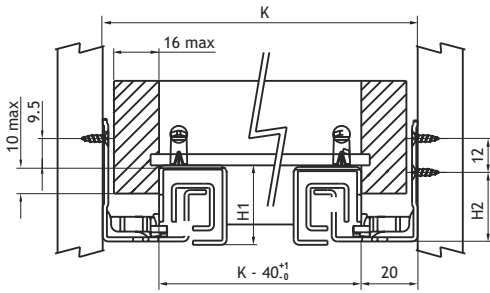

Modelo	H1	H2
Excel extração parcial	20,5	18
Excel extração total	28,2	24,5

Dimensões para instalação

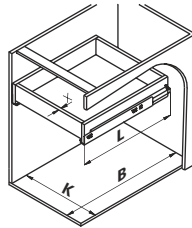

A= profundidade da gaveta.
L= comprimento nominal da corrediça
B= profundidade interna do móvel
K= largura interna do móvel

Dimensões internas do Móvel:
gaveta com frontal : B min=L+3mm
gaveta interna : B min=L+21mm

Dimensões da gaveta

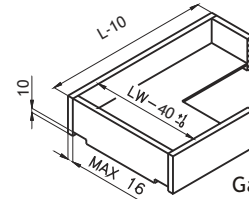

Gaveta com frontal
Profundidade= L-10

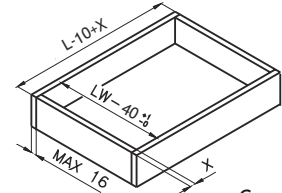

Gaveta interna
Profundidade= L-10+X

Furação para fixação

Extração total - excel ET N650H

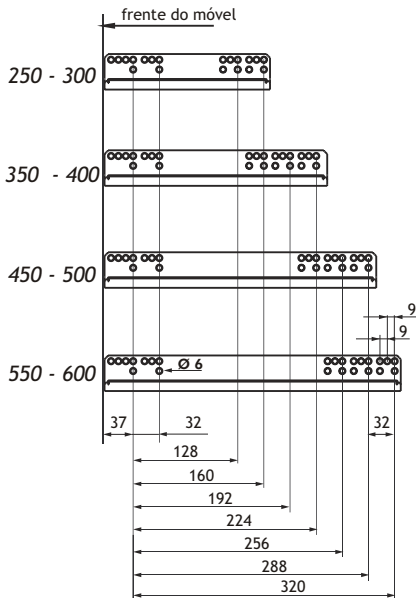

Extração parcial - excel EP N550H

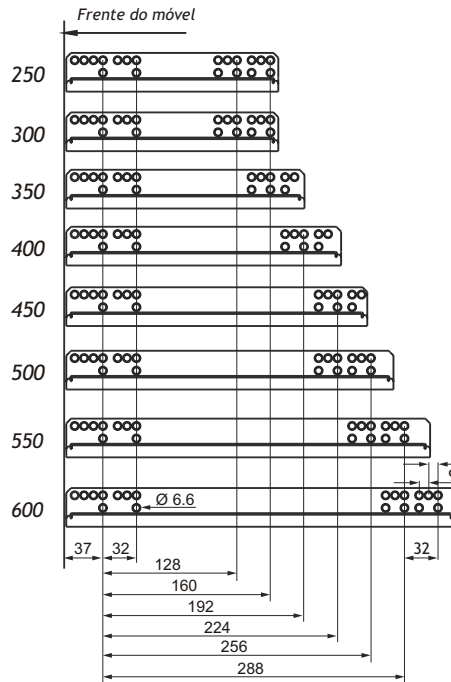

gaveta com frontal

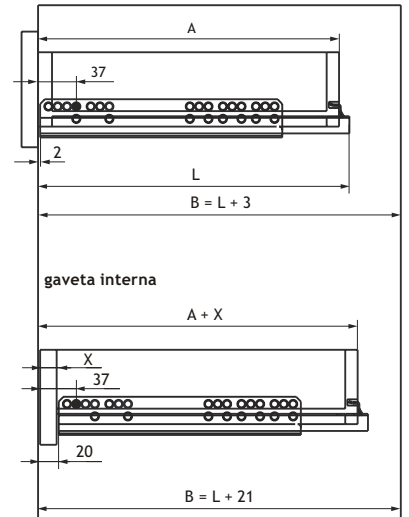

gaveta interna

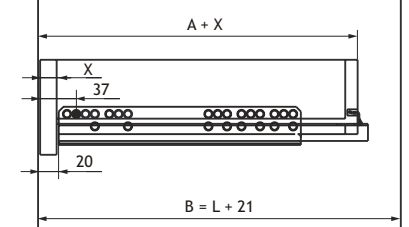

Dimensões e furação da gaveta

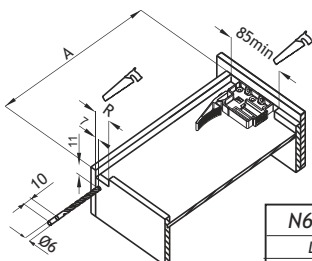

Extração total R= 28mm
Extração parcial R= 18mm

N650H / N550H	
L	A
260	250
310	300
360	350
410	400
460	450
510	500
560	550
610	600

Montagem do sistema Easy-Fix

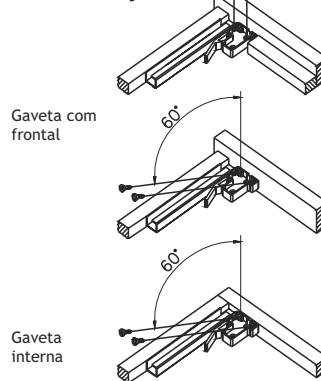

Parafusos

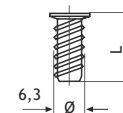

Parafuso Euro
Cod. 1A07510128000 L = 12
Cod. 1A07511505000 L = 15

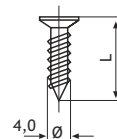

Parafuso Fixer
Cod. 1A03503415000 L = 12
Cod. 1A0350342500B L = 15